

Full Band Tunable DFB Laser Module



Applications

- Long Haul or Metropolitan DWDM Transmission Systems
- Dynamic Wavelength Provisioning and Add/Drop Multiplexer

Descriptions

- FRL15TCWx-D86 series is full band tunable DFB laser module designed for long haul DWDM applications with external intensity modulator.
- The polarization maintaining fiber pigtail enables to directly connect a modulator without polarization control. The polarization state of output laser beam is maintained to a consistent orientation.
- Full band thermally tunable DFB laser diode chip is integrated with an optical isolator, thermo-electric coolers (TEC), thermistors, a power monitor photodiode, and a wavelength monitor photodiode in a hermetically sealed 26 pin butterfly package with same foot print as an industry standard 14 pin butterfly package.
- Full band thermally tunable DFB laser diode chip consists of DFB laser array and semiconductor optical amplifier (SOA). Each DFB laser is biased under constant current and output power is maintained by adjusting SOA current under automatic power control. By selecting an appropriate DFB laser and tuning the laser temperature, FRL15TCWx-D86 series can provide any ITU channel in 35 nm tuning range.
- This laser module complies with telecom requirements described in Telcordia™ GR-468 and is manufactured in an ISO™9001 certified production line.

Features

- 35nm tunability (88 ITU channels at 50GHz spacing) available in C or L band
- Stable wavelength with integrated wavelength monitor
- High optical output power up to 20mW for C band
- High side mode suppression ratio(SMSR) in entire tuning range
- 26 pin butterfly package
- Low TEC power consumption
- Polarization maintaining fiber pigtail
- RoHS compliant package

Absolute Maximum Ratings

Parameters	Symbol	Min.	Max.	Unit	Conditions
Storage Temperature	T _{stg}	-40	85	°C	
Operating Case Temperature	T _c	-5	70	°C	
LD Operating Temperature	T _{LD}	8	52	°C	
Filter Operating Temperature	T _f	30	55	°C	
LD Forward Current	I _{fLD}	-	200	mA	
LD Reverse Voltage	V _{rLD}	-	2	V	
SOA Forward Current	I _{fSOA}	-	400	mA	
SOA Reverse Voltage	V _{rSOA}	-	2	V	
PD Forward Current	I _{fPD}	-	5	mA	
PD Reverse Voltage	V _{rPD}	-	20	V	
TEC1 Current (LD)	I _{tec1}	-	1.4	A	
TEC1 Voltage (LD)	V _{tec2}	-	3.4	V	
TEC2 Current (Filter)	I _{tec1}	-	2.1	A	
TEC2 Voltage (Filter)	V _{tec2}	-	5.1	V	
Relative Humidity	RH	0	85	%	
Fiber Bend Radius	-	30	-	mm	
Fiber Axial Pull Force	-	-	10	N	
Lead Soldering Temperature	-	-	350	°C	
Lead Soldering Duration	-	-	10	sec	
Torque Force	-	-	0.1	Nm	Flatness : <20μm
Electrostatic Discharge (ESD)	-	-	500	V	HBM, C=100pF, R=1.5kΩ

Specifications ($T_C=25^\circ\text{C}$, BOL*¹ unless otherwise specified)

Parameters	Symbol	Min.	Typ.	Max.	Unit	Conditions
Optical Output Power	Pf	10 20			mW	CW 20mW is available only for -19610.
FRL15TCWA						
FRL15TCWB						
LD Operating Temperature	T_{LD}	10	-	50	$^\circ\text{C}$	Rated power, CW
LD Forward Current	I_{fLD}	-	150	-	mA	CW, fixed
LD Forward Voltage	V_{fLD}	-	-	2.2	V	CW
SOA Forward Current	I_{fSOA}	-	-	350	mA	Rated power, CW
SOA Forward Voltage	V_{fSOA}	-	-	3.0	V	Rated power, CW
Wavelength	λ	1528.773 - 1563.455 1570.416 - 1607.035			nm	Rated power, CW 50GHz spacing, 88ch
-19610 (C band)						
-19090 (L band)						
Linewidth (-3dB fullwidth)	$\Delta\lambda$	-	-	10	MHz	Rated Power, CW
Side Mode Suppression Ratio	SMSR	35	-	-	dB	Rated power, CW
Optical Isolation	Iso	25	-	-	dB	
Relative Intensity Noise	RIN	-	-	-135	dB/Hz	Rated power, CW $O_{pRL} < -25\text{dB}^{*2}$ 100MHz < f < 10GHz
Frequency Stability to ITU Grid	Δf_s	-2.5	-	2.5	GHz	Rated Power
Filter Operating Temperature	T_f	35	-	50	$^\circ\text{C}$	
Free Spectral Range * ³	FSR	-	50	-	GHz	
Capture Range * ³ (negative side)	-CR	5	-	35	GHz	
Capture Range * ³ (positive side)	+CR	15	-	45	GHz	
Power Monitor Current	I_m	10	-	500	μA	Rated power, CW $V_{rPD}=5\text{V}$
Power Monitor Dark Current	I_d	-	-	100	nA	$V_{rPD}=5\text{V}$
Wavelength Monitor Current	$I_{m\lambda}$	10	-	500	μA	Rated power, CW $V_{rPD}=5\text{V}$
Wavelength Monitor Dark Current	$I_{d\lambda}$	-	-	100	nA	$V_{rPD}=5\text{V}$
Wavelength Monitor Current Slope * ³	Slope	1	-	40	$\mu\text{A}/\text{GHz}$	$V_{rPD}=5\text{V}$
Tracking Error	TE	-0.5	-	0.5	dB	$I_m=\text{constant}$, $T_c=-5$ to 70°C
TEC Current (LD)	I_{tec1}	-	-	1.2	A	$T_c=70^\circ\text{C}$, Rated power, CW
TEC Voltage (LD)	V_{tec1}	-	-	3.0	V	$T_c=70^\circ\text{C}$, Rated power, CW
TEC Current (Filter)	I_{tec2}	-	-	1.7	A	$T_c=70^\circ\text{C}$, Rated power, CW
TEC Voltage (Filter)	V_{tec2}	-	-	3.0	V	$T_c=70^\circ\text{C}$, Rated power, CW
Total Power Consumption ($P_{LD}+P_{SOA}+P_{TEC1}+P_{TEC2}$)	P_{total}	-	3.0	4.5	W	$T_c=70^\circ\text{C}$, Rated power, CW
Thermistor B constant	B	-	3900	-	K	
Thermistor Resistance	R	9.5	-	10.5	k Ω	$T_{LD}=25^\circ\text{C}$
Polarization Extinction Ratio	E_r	20	-	-	dB	Rated power, CW

*1 BOL : Beginning of Life

*2 O_{pRL} : Optical Return Loss

*3 These parameters are defined in following wavelength discriminator curve.

Dimensions and Pin Assignments

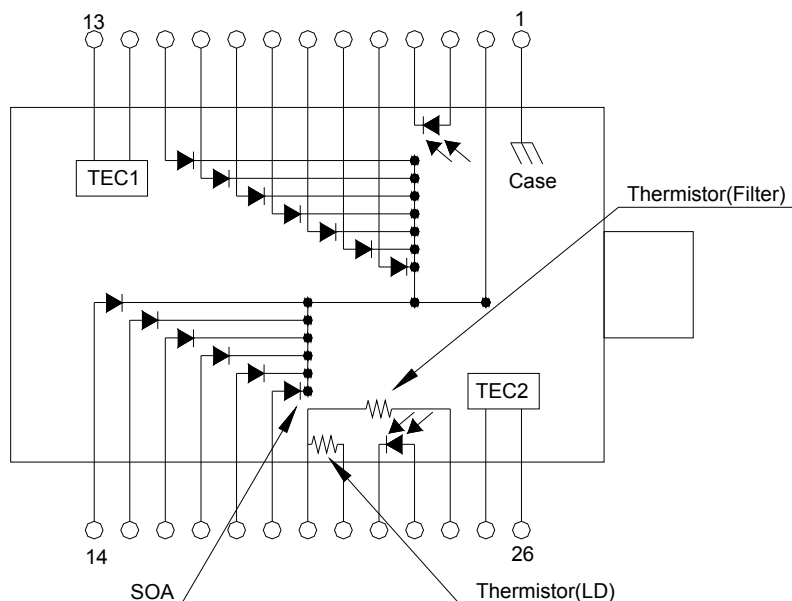
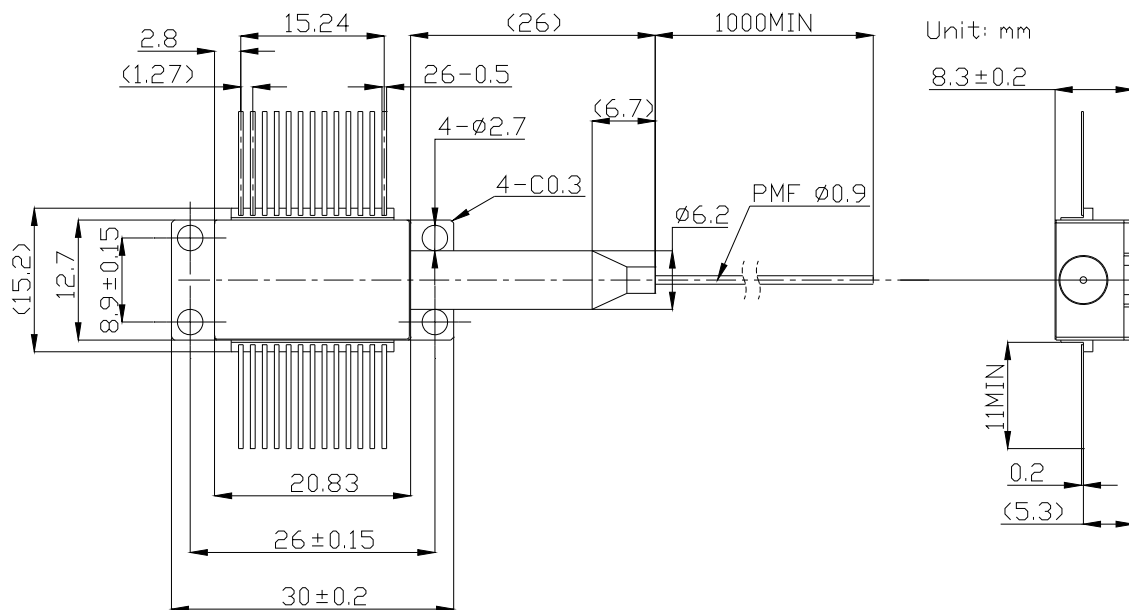

Pin No.	Function	Pin No.	Function
1	Case Ground	14	LD6 Anode(+)
2	LD, SOA Cathode Common(-)	15	LD5 Anode(+)
3	Power Monitor PD Anode(-)	16	LD4 Anode(+)
4	Power Monitor PD Cathode(+)	17	LD3 Anode(+)
5	LD1 Anode(+)	18	LD2 Anode(+)
6	LD12 Anode(+)	19	SOA Anode(+)
7	LD11 Anode(+)	20	Thermistor Common
8	LD10 Anode(+)	21	Thermistor(LD)
9	LD9 Anode(+)	22	Wavelength Monitor PD Cathode(+)
10	LD8 Anode(+)	23	Wavelength Monitor PD Anode(-)
11	LD7 Anode(+)	24	Thermistor(Filter)
12	TEC1(LD)(+)	25	TEC2(Filter)(+)
13	TEC1(LD)(-)	26	TEC2(Filter)(-)

Optical Fiber Pigtail Specifications

Parameters	Specification	Unit
Fiber Type	Polarization maintaining(PANDA) fiber Flame retardant Hytel™ coating(φ0.9mm)	-
Nominal Fiber Length	Min.1,000	mm
Connector Type	No Connector	-
Polarization Axis	Slow Axis	-

Ordering Information

FRL15TCW□ – D86 - □□□□□

Optical Output Power
A: 10mW
B: 20mW (19610 only)

Wavelength code
19610: C band
19090: L band

Safety Information

This product complies with 21 CFR 1040.10 and 1040.11, Class 3b laser product. Invisible laser radiation is emitted from the end of the fiber or connector. Avoid direct exposure to the beam.



Telcordia is a trademark of Telcordia Technologies, Inc.
ISO is a trademark of The International Organization for Standardization.
Hytel is a trademark of DuPont.

Furukawa Electric reserves the right to improve, enhance and modify the features and specifications of FITELE products without prior notifications.

THE FURUKAWA ELECTRIC CO., LTD.

Japan
Head Office
 2-2-3, Marunouchi
 Chiyoda-ku
 Tokyo 100-8322, JAPAN
 Tel: +81-3-3286-3253
 Fax: +81-3-3286-3978
<http://www.furukawa.co.jp>
 Email:comsales@ho.furukawa.co.jp

North America
OFS Fitel, LLC
Specialty Photonics Division
 25 Schoolhouse Road
 Somerset, NJ 08873 USA
 Tel: +1-732-748-7402
 Fax: +1-732-748-7436
<http://www.SpecialtyPhotonics.com>
 E-mail:info@SpecialtyPhotonics.com

Europe
Furukawa Electric Europe Ltd.
 3rd Floor, Newcombe House
 43-45 Notting Hill Gate
 London W11 3FE, UK
 Tel: +44-20-7221-6000
 Fax: +44-20-7313-5310
<http://www.furukawa-fitel.co.uk>
 E-mail:sales@furukawa-fitel.co.uk

ASIA
Furukawa Electric Hong Kong Ltd.
 Suite 2606, Shell Tower,
 Times Square,1 Matheson Street,
 Causeway Bay, Hong Kong
 Tel: 852-2512-8938
 Fax: 852-2512-9717
<http://www.fehk.com.hk/>
 E-mail: guest@fehk.cn