

# 62-C

## 62-C type

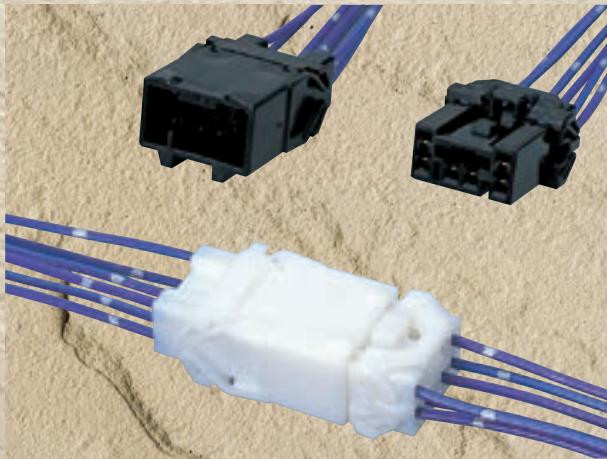

従来のコネクタに比べ優れた接触信頼性を有した1.5mmタブサイズ（ピッチ：3.3）超小型非防水コネクタです。

1.5mm tab size (3.3 pitch) super-small multi-pole connector with superior connection reliability compared to previous connectors.

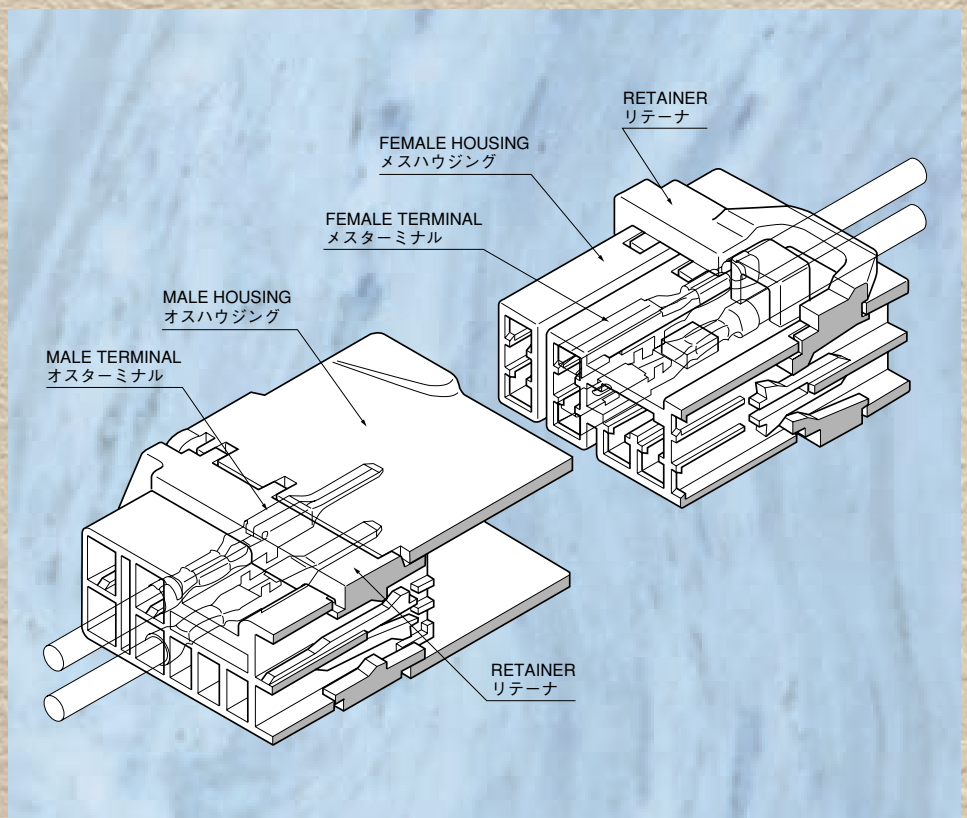

# 62-C CONNECTOR

## 62-C type

## 特長

62-Cコネクタは、タブサイズ1.5mmの端子を採用した高性能超小型多極コネクタです。最大極数16を有し、ハウジングロック機構には、不完全挿入のない慣性ロック構造を採用し、二重係止にヒンジ一体方式のリテーナを採用する事により、端子の不完全挿入防止と、接続の信頼性、作業性を一段と向上させたコネクタです。

## CHARACTERISTICS

The 62-C connector is a high performance small-size multi-pole connector employing 1.5mm tab size terminals. With a maximum 16 poles, and through employment of a housing Inertia lock mechanism that eliminates incomplete insertion, as well as a hinged retainer in the dual retention system, connection reliability/workability and prevention of incomplete terminal insertion has been greatly improved.

## 性能

- 1) 適用電線  
AVS, CAVS 0.2~0.85mm<sup>2</sup>  
(A.W.G.#24~#18)
- 2) ハウジングロック強度  
98 N以上
- 3) 端子保持力  
98 N以上
- 4) 許容電流  
6 A (AVS 0.5mm<sup>2</sup>, 8/16 極通電時)
- 5) 電圧降下  
初期 5 mV/A以下  
耐久後 10 mV/A以下
- 6) 耐電圧  
AC 1,000V/分

## SPECIFICATIONS

- 1) **Applicable wire types :**  
AVS, CAVS 0.2~0.85mm<sup>2</sup>  
(A.W.G.#24~#18)
- 2) **Housing lock Strength :**  
At least 98N
- 3) **Terminal to Housing lock Strength :**  
At least 98N
- 4) **Permissible current :**  
6A (AVS 0.5mm<sup>2</sup>, flowing to  
8/16 poles Conducting)
- 5) **Voltage Drop :**  
Initial 5mV/A (max)  
After durability 10mV/A (max)
- 6) **Withstand voltage :**  
AC 1,000V/min

## オス端子 MALE TERMINAL

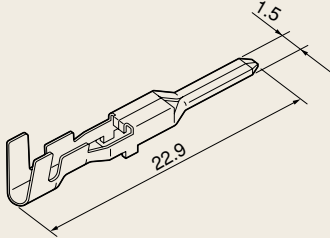
適用電線 WIRE SIZE	端子名称 TERMINAL NAME	形状 FORM	部品番号 PART No.
AVS 0.3mm <sup>2</sup> AV, CAVS 0.3mm <sup>2</sup>	CM-0.2		MT091-30030
AVS, CAVS 0.5~0.85mm <sup>2</sup> AV 0.5mm <sup>2</sup>	CM-0.5		MT091-30830
AVS 0.3mm <sup>2</sup> AV, CAVS 0.3mm <sup>2</sup>	CM-0.2-AU		MT091-30060
AVS, CAVS 0.5~0.85mm <sup>2</sup> AV 0.5mm <sup>2</sup>	CM-0.5-AU		MT091-30860

## メス端子 FEMALE TERMINAL

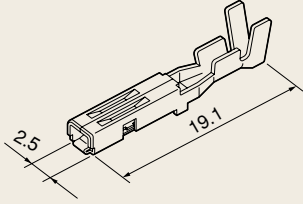
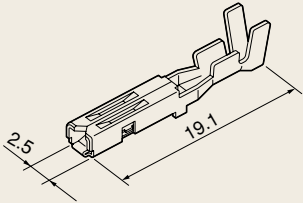
適用電線 WIRE SIZE	端子名称 TERMINAL NAME	形状 FORM	部品番号 PART No.
AVS 0.3mm <sup>2</sup> AV, CAVS 0.3mm <sup>2</sup>	CF-0.2		MT095-30080
AVS, CAVS 0.5~0.85mm <sup>2</sup> AV 0.5mm <sup>2</sup>	CF-0.5		MT095-30880
AVS 0.3mm <sup>2</sup> AV, CAVS 0.3mm <sup>2</sup>	CF-0.2-AU		MT095-30060
AVS, CAVS 0.5~0.85mm <sup>2</sup> AV 0.5mm <sup>2</sup>	CF-0.5-AU		MT095-30860



## オスハウジング MALE HOUSING

## オスハウジング MALE HOUSING

2P

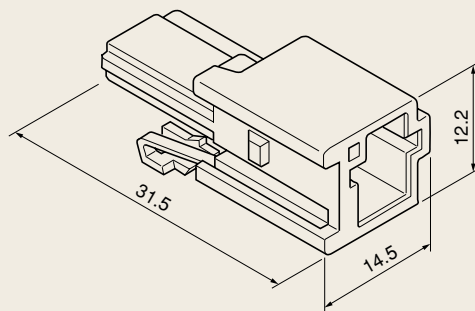
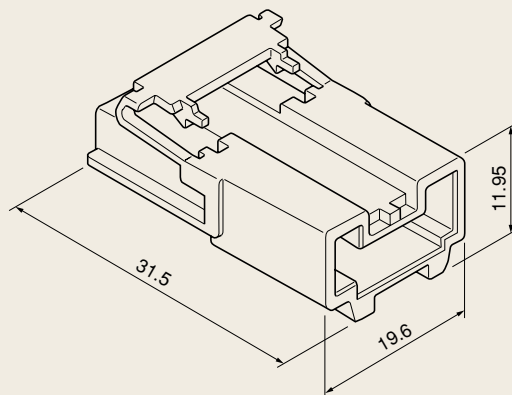
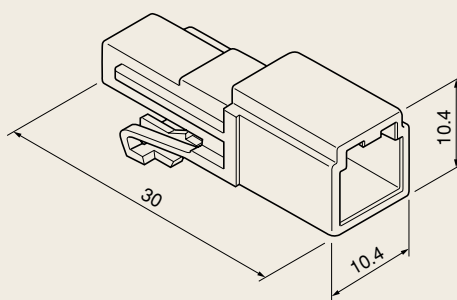
C02M-W  
PH851-02010C02M-B  
PH851-02020C02M-BR  
PH851-02050

# メスハウジング FEMALE HOUSING

## メスハウジング FEMALE HOUSING

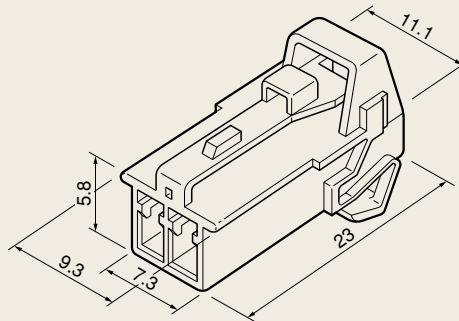
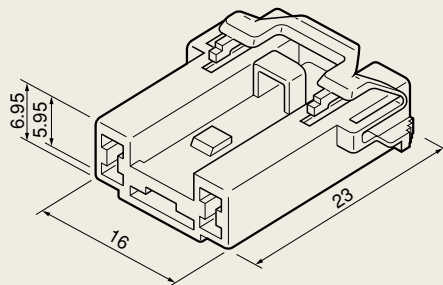
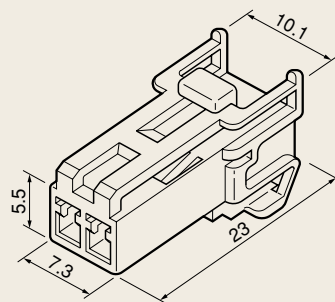
**2P****C02F-W  
PH855-02010****C02F-B  
PH855-02020****C02F-BR  
PH855-02050**

# HOUSING

62-C

## オスハウジング MALE HOUSING

オスハウジング MALE HOUSING

4P

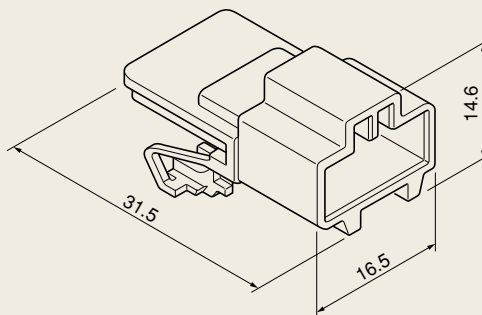
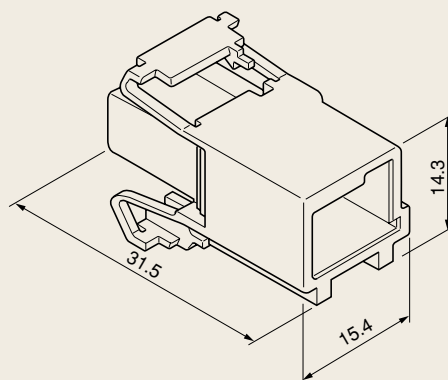
C04M-W  
PH851-04010C04M-B  
PH851-04020

# メスハウジング FEMALE HOUSING

メスハウジング FEMALE HOUSING

4P

C04F-B  
PH855-04020

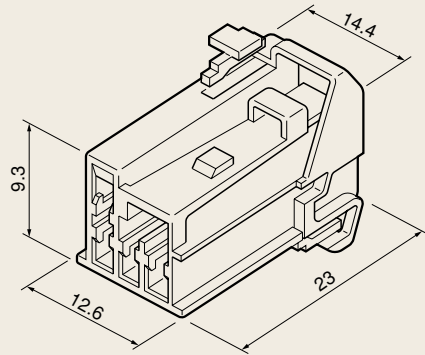

HOUSING

## オスハウジング MALE HOUSING

## オスハウジング MALE HOUSING

6P

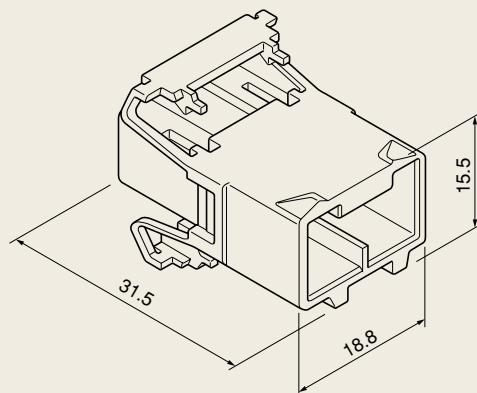
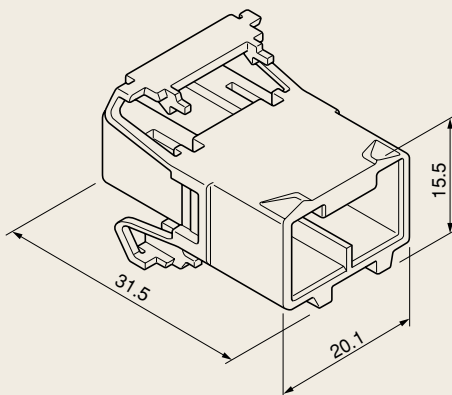
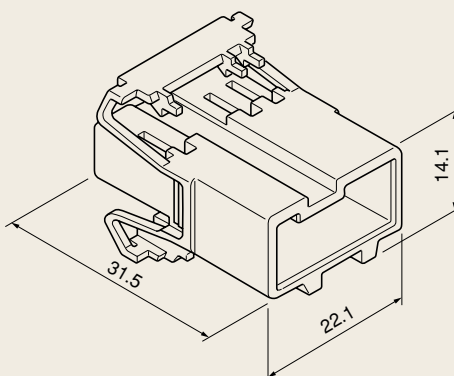
C06M-W  
PH851-06010C06M-B  
PH851-06020C06M-BR  
PH851-06050

8P

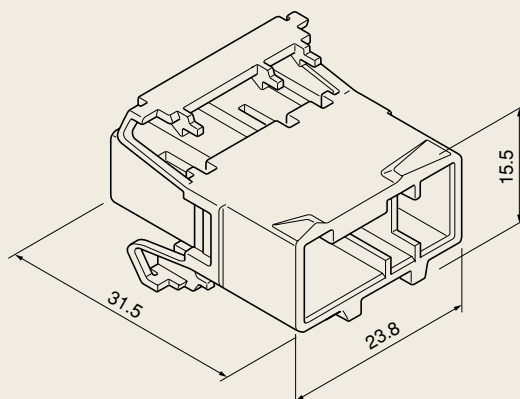
C08M-W  
PH851-08010



# メスハウジング FEMALE HOUSING

## メスハウジング FEMALE HOUSING

6P

C06F-W  
PH855-06010

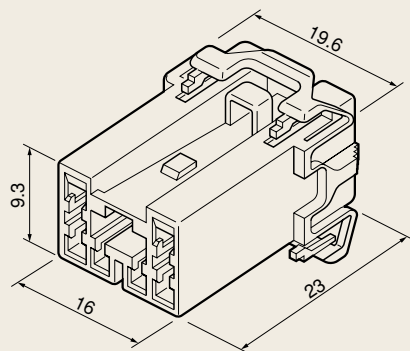

C06F-B  
PH855-06020

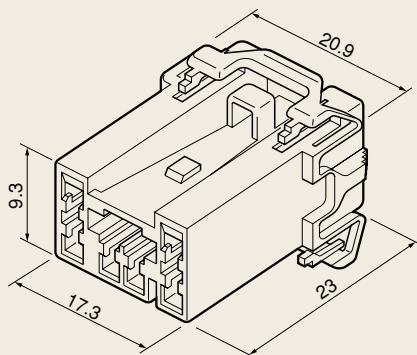

C06F-BR  
PH855-06050

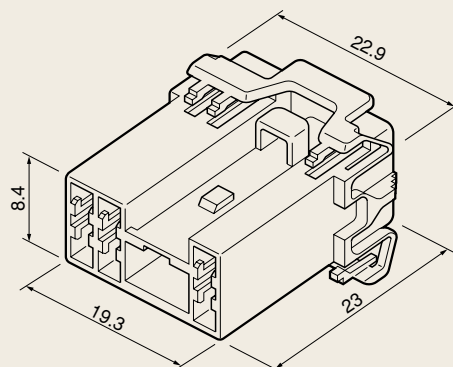

8P

C08F-W  
PH855-08010

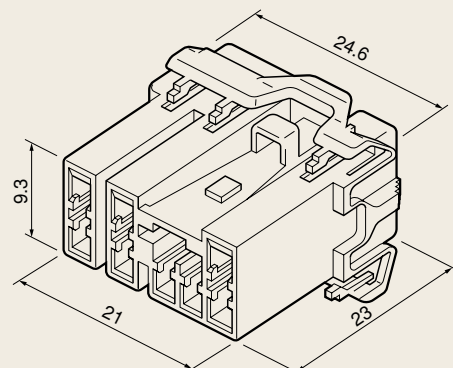

HOUSING

62-C

## オスハウジング MALE HOUSING

オスハウジング MALE HOUSING

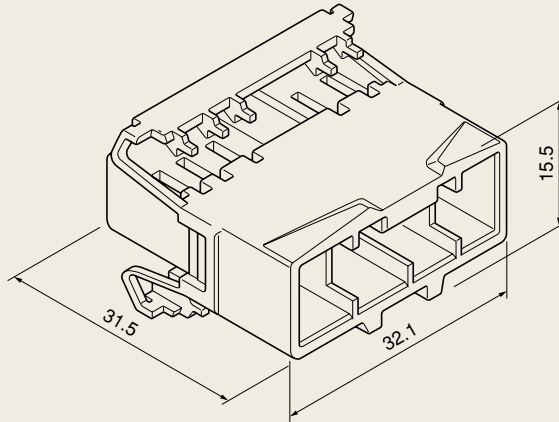
**12P** C12M-W  
PH851-12010

## メスハウジング FEMALE HOUSING

メスハウジング FEMALE HOUSING

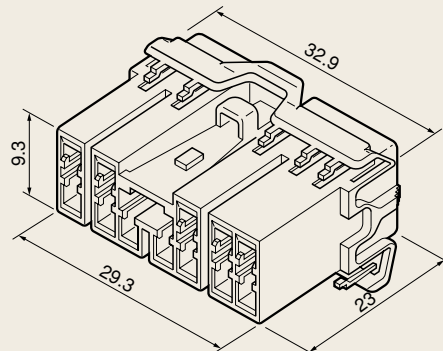
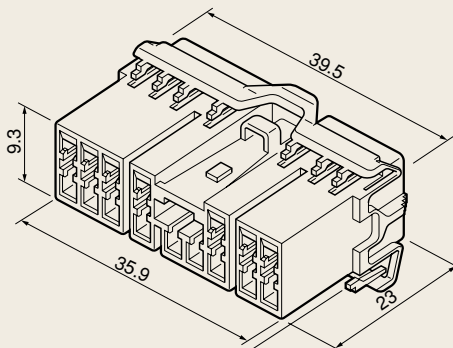
**12P** C12F-W  
PH855-12010**16P** C16F-W  
PH855-16010

# 基板直付けタイプ Direct-on-board installation type

基板用コネクタ ON-BOARD CONNECTOR

プリント基板穴位置 HOLE POSITION OF PRINT BOARD

**3P**

**C03V-W ASS'Y**  
PH852-03011

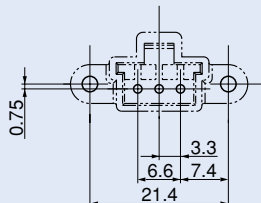
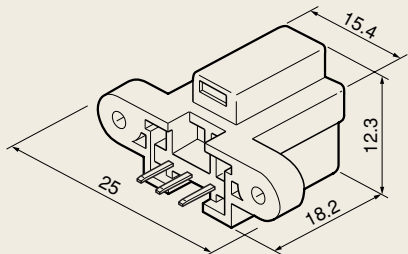

**C03H-W ASS'Y**  
PH853-03011

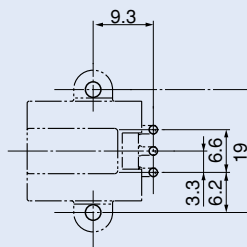
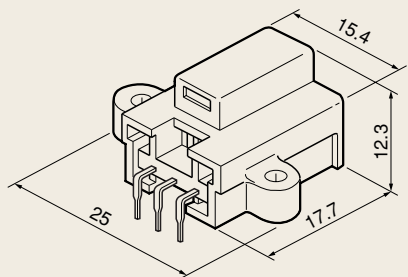

HOUSING

# 基板直付けタイプ Direct-on-board installation type

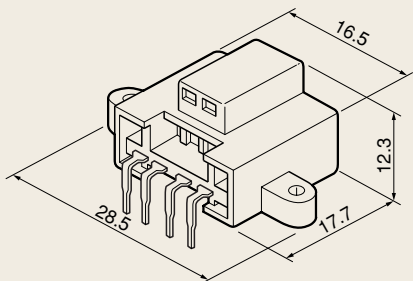
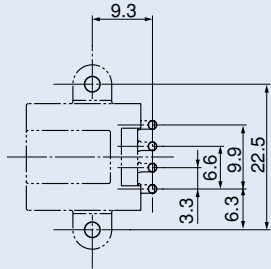
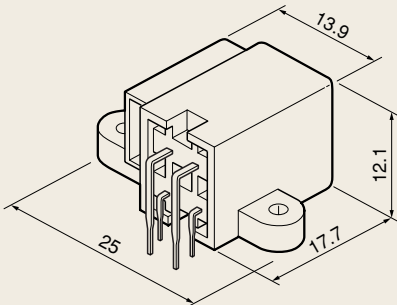
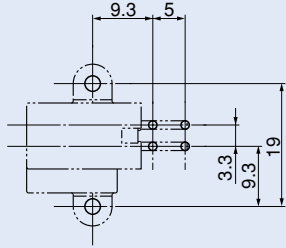
基板用コネクタ ON-BOARD CONNECTOR		プリント基板穴位置 HOLE POSITION OF PRINT BOARD	
4P	<b>C04H-W ASS'Y</b> <b>PH853-04011</b> 		
	<b>C04H-BR ASS'Y</b> <b>PH853-04051</b> 		

# 基板直付けタイプ Direct-on-board installation type

基板用コネクタ ON-BOARD CONNECTOR

プリント基板穴位置 HOLE POSITION OF PRINT BOARD

6P

C06V-B ASS'Y  
PH852-06021

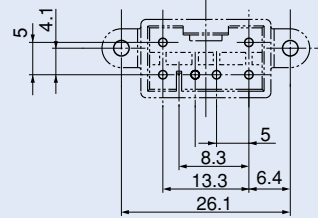
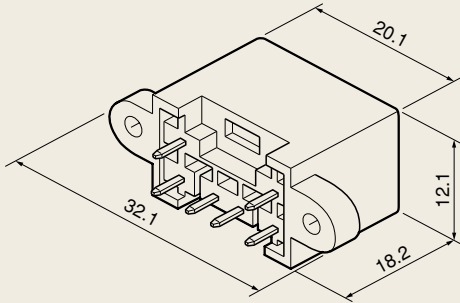

C06H-B ASS'Y  
PH853-06021

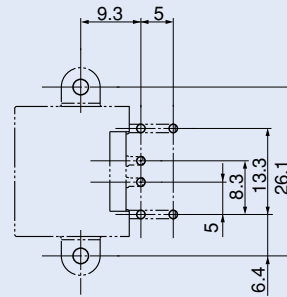
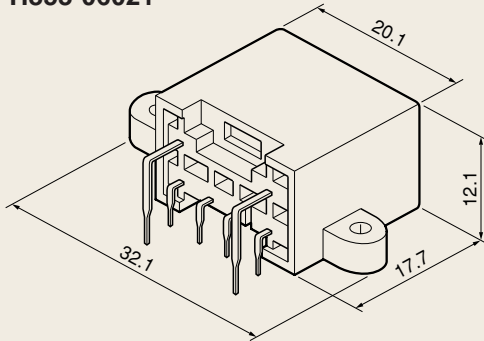

HOUSING

62-C

## 基板直付けタイプ Direct-on-board installation type

基板用コネクタ ON-BOARD CONNECTOR

プリント基板穴位置 HOLE POSITION OF PRINT BOARD

8P

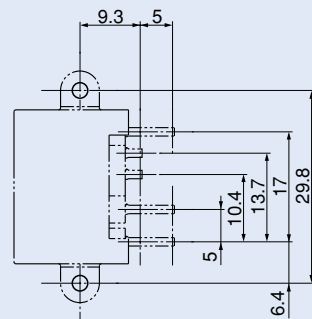
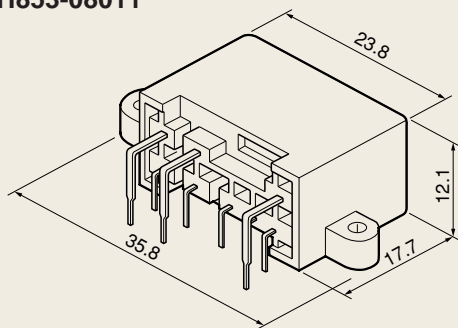
C08H-W ASS'Y  
PH853-08011



# 基板直付けタイプ Direct-on-board installation type

基板用コネクタ ON-BOARD CONNECTOR

プリント基板穴位置 HOLE POSITION OF PRINT BOARD

12P

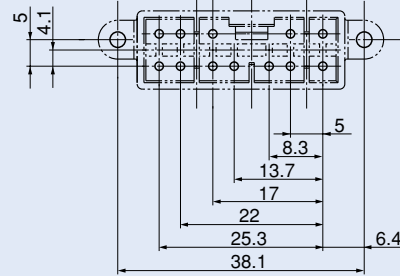
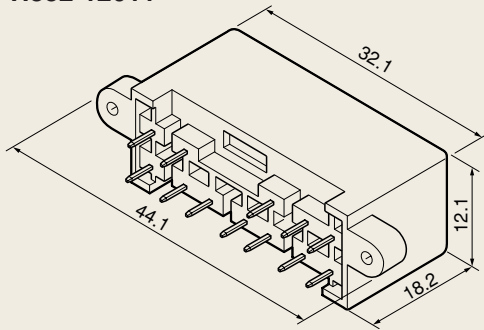
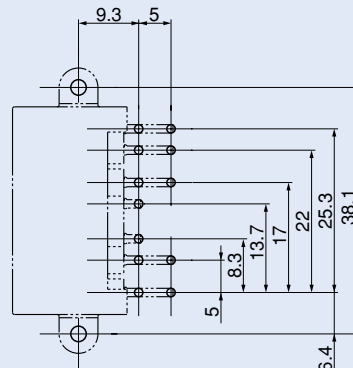
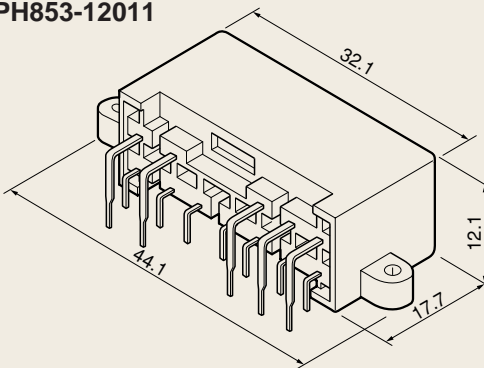
C12V-W ASS'Y  
PH852-12011C12H-W ASS'Y  
PH853-12011

HOUSING

